

Ardron-Mackie

Eco-Shelf LED Display

LED Shelf Talker

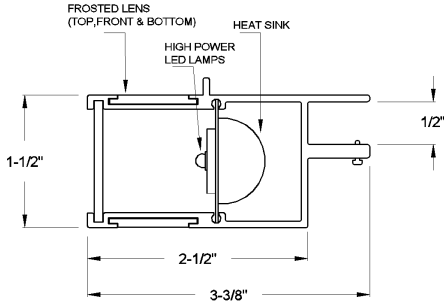

Description

- Linear shelf light with 3 Watt LED lamp and electronic driver
- Proprietary LED board design provides individual LED monitoring for uniform power and full lifespan
- 2 wire operation—safe, low voltage 24V DC operation
- 100,000 hour life*
- Built-in surge/transient protection—preventing harmful effects from brownout/blackout or inconsistent power supplies
- Reverse protection—prevents damage from incorrect installation
- Proprietary extrusion design for optimum thermal management
- Up to 815 Lumens per foot
- Up/Down & Face Illumination
- Custom Logo on shelf face (by others)

Housing & Available finishes

- Extruded aluminum housing and aluminum end plates
- Powder coated white gloss
- Other finishes available
- Custom sizes available

Mounting Options

- Remote driver in approved enclosure
- Simple thumb screw attachment to solid or glass shelving systems
- Plug & Play system for existing shelving
- 'Wireless' system available

Lamp & Driver

- LED lamps included
- UV free light output
- 100,000 hour lamp life*
- Electronic driver provides constant current

Applications

- Drug Stores, Grocery Stores, Convenience Stores, Cosmetics, Hardware

Part #

B42300 G - -

LEDs
@ 1 per 2.66"

Fixture Length

Color Temperature
W—Warm (3000—3500K)
N—Neutral (4000—4500K)
W—Cool (5000—5500K)



<http://www.ardron.com>

1-800-509-0222

© 2008 Ardron-Mackie Limited

The 'Go Green' symbol indicates environmentally friendly products. The 'Certified' symbol indicates Certified Lumileds Manufacturer.

Specifications subject to change without notice